

Flettner '2000' Ventilator



Thank you for purchasing the definitive wind powered rotary ventilator. The Flettner '2000' provides maintenance-free air extraction and is designed to be tough and durable. Properly installed, it will provide years of problem-free ventilation.

VERY IMPORTANT -

Read this first

Adequate ventilation is vital. It is the responsibility of the fitter and the customer to establish the amount of air extraction that is required for each application, and to ensure that the positioning and the number of ventilators fitted are suitable

As a guideline only air extraction rates measured by MIRA Ltd. are published on the Flettner Ventilator web site: www.flettner.co.uk These are provided purely for illustrative purposes as the extraction rates achieved are dependent upon the precise configuration of each application.

The performance of the Flettner '2000' will be impaired if it is fitted to a sealed vehicle compartment or to a building with no independent air inlet. In such situations an air inlet such as a grille should be fitted in addition to the Flettner '2000' in order to provide an adequate path for air extraction to occur.

If the ventilator is used to extract hazardous vapours then continuous ventilation is required. In such circumstances the shutter should not be fitted in order to prevent accidental closure.

Figure 1 - Contents

The following items are supplied as part of the Flettner 2000 Ventilator.

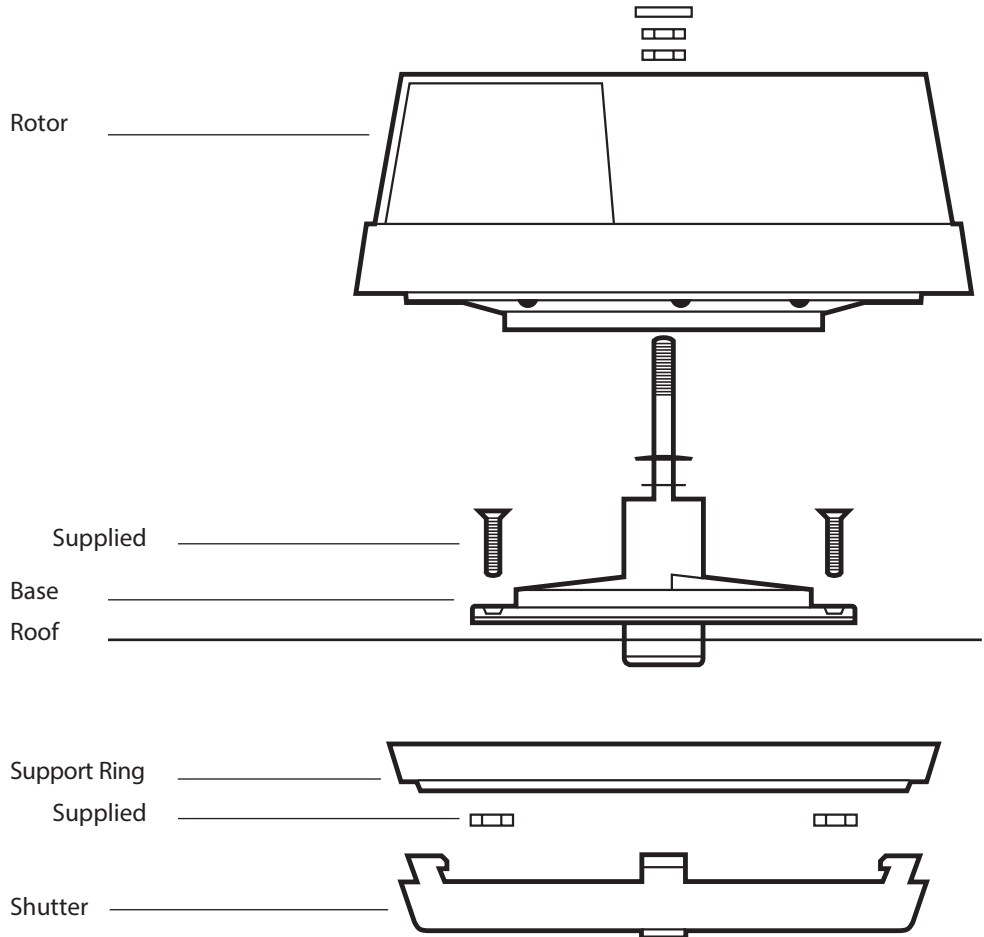

Flettner Ventilator Ltd

Studio 214, Milton Keynes Business Centre, Linford Wood, Milton Keynes, MK14 6GD, UK

Tel: +44 (0)1908 698901 www.flettner.co.uk sales@flettner.co.uk

Flettner is a trademark of Flettner Ventilator Ltd

Fitting Instructions

If the ventilator is to be fitted to a ribbed section of a roof ensure that the base of the ventilator can sit flush on the roof surface between the ribs, and that the position chosen will permit the support ring (if fitted) to sit flush with the underside of the roof.

The Flettner '2000' ventilator cannot be fitted without adaptation to roofs where the spacing between raised ribs is less than 5.75" (145mm). However an alternative model, the Flettner TCX-2™ ventilator (narrow base version), can be fitted to roofs where the spacing between raised ribs is as small as 4.25" (108mm). See www.flettner.co.uk for details.

For double skinned roofs an adaptor (optional extra) should be used.

1. Prise the grey disc from the top of the rotor using a small screwdriver
2. Remove the locking nut using a 1/2 inch or 13mm socket spanner (socket wrench) or box spanner. To facilitate disassembly the locking nut has not been tightened down fully. However it must be fully tightened when the ventilator is fitted.
3. Hold rotor and unscrew second nut using a screwdriver inserted in the slot at the top of the spindle.
IMPORTANT : Turn the screwdriver clockwise to release the nut.
4. Using the template provided (figure 2) mark out on a flat section of the roof the hole pattern - four fixing holes and one large central hole. Ensure that the position chosen allows sufficient clearance in each direction for the base and rotor to be located properly.
5. Cut the large 3.78"(96mm) diameter circular hole as shown on figure 2 . Remove any burr from the cut edges.
6. Drill the four 0.2" (5mm) diameter fixing holes. The centres of the opposite pairs of holes should be 4.88" (124mm) apart, equally spaced on either side of the large hole on a line passing through the centre of it.
7. Use an appropriate rust-inhibiting preparation to treat any bare metal surfaces.
8. Place the base (with gasket in place) on the roof and push the four bolts provided through the fixing holes. The length of the bolts should be chosen to avoid their obstructing the shutter, if fitted.
9. Offer up the support ring, if fitted, to the underside of the roof passing the bolts through the four holes. Where roof is double skinned an adaptor (optional extra) or collar can be used to bridge the roof cavity between the ventilator and the support ring.
10. Tighten the four bolts using the nuts provided.
11. Clip shutter to the support ring.
(Note: the shutter is not essential to the operation of the ventilator and can be omitted if continuous ventilation is required).
12. Place rotor on the shaft and secure with both nuts. The lower nut should be hand threaded onto the spindle clockwise and then gently tightened into position by turning the spindle anti-clockwise with a screwdriver. Firmly tighten the locking nut (upper nut) clockwise onto the lower nut.
13. Press the grey disc home into position.



Flettner Ventilator Ltd

Studio 214, Milton Keynes Business Centre, Linford Wood, Milton Keynes, MK14 6GD, UK
Tel: +44 (0)1908 698901 www.flettner.co.uk sales@flettner.co.uk

Flettner is a trademark of Flettner Ventilator Ltd

Figure 2 - Actual Size Template for Flettner '2000' Base

Key

⊕ Small fixing holes

■ Extent and position of large hole to be cut

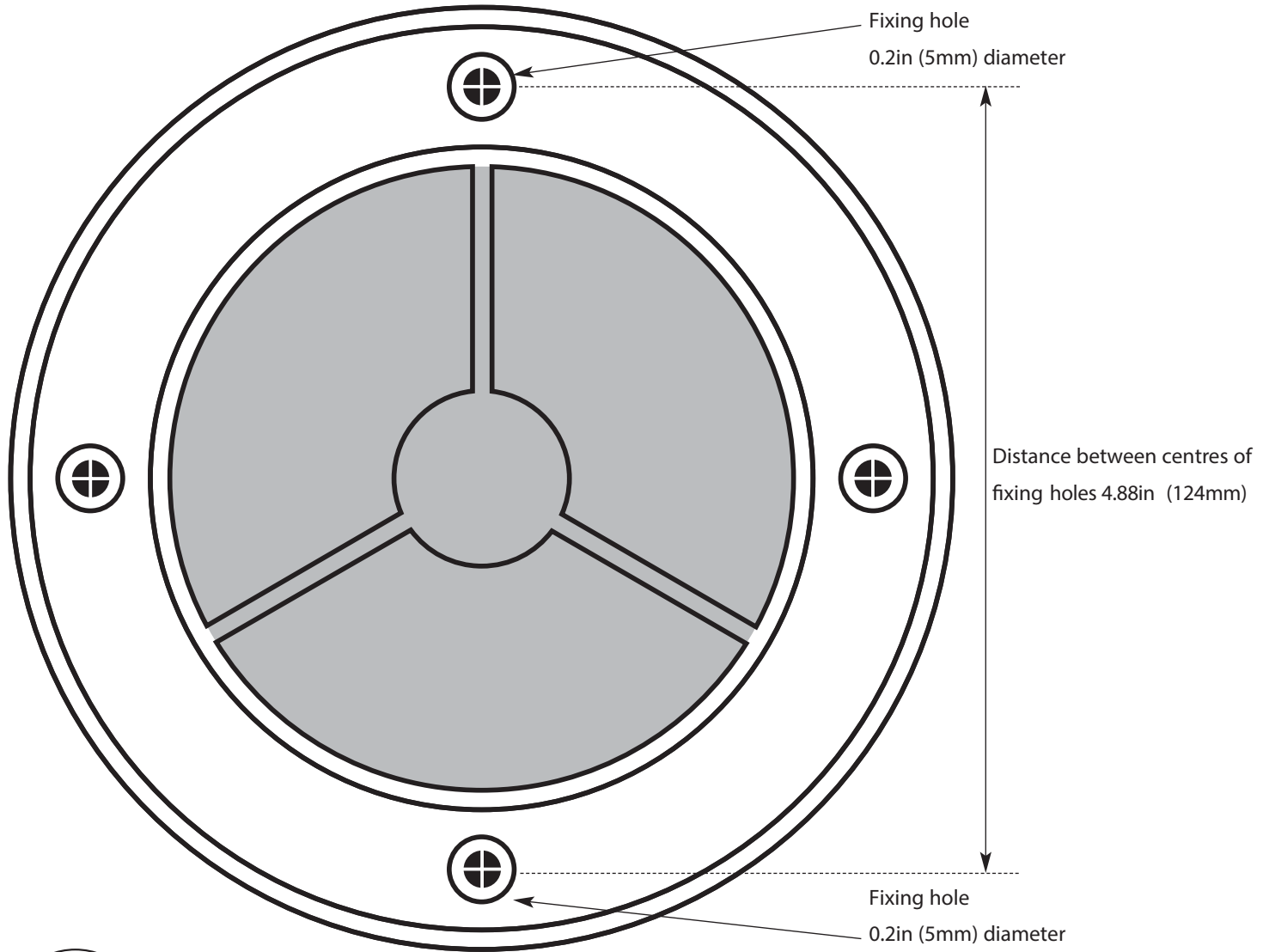

Flettner Ventilator Ltd

Studio 214, Milton Keynes Business Centre, Linford Wood, Milton Keynes, MK14 6GD, UK
Tel: +44 (0)1908 698901 www.flettner.co.uk sales@flettner.co.uk

Flettner is a trademark of Flettner Ventilator Ltd



Flettner Ventilator Ltd

Studio 214, Milton Keynes Business Centre, Linford Wood, Milton Keynes, MK14 6GD, UK
Tel: +44 (0)1908 698901 www.flettner.co.uk sales@flettner.co.uk

Flettner is a trademark of Flettner Ventilator Ltd